

NOTE:

1. ALL RAILS TO BE SUPPLIED PREFABRICATED TO REQUIRED LENGTH W/ FACTORY INSTALLED END PLATES.
2. BRACKET SPACING NOT TO EXCEED 32" [812.8] ON CENTER.
3. ALL MOUNTING HARDWARE TO BE SUPPLIED BY OTHER FOR FIELD ASSEMBLY AND INSTALLATION.
4. INSIDE & OUTSIDE CORNERS ARE NOT AVAILABLE. ALL RUNS MUST BE TERMINATED AT INSIDE & OUTSIDE CORNERS.
5. MATERIAL:
CS5V CRASH RAIL SHALL BE MANUFACTURED FROM 16 GA. STAINLESS STEEL, TYPE 304 ALLOY W/ V-GROOVE.

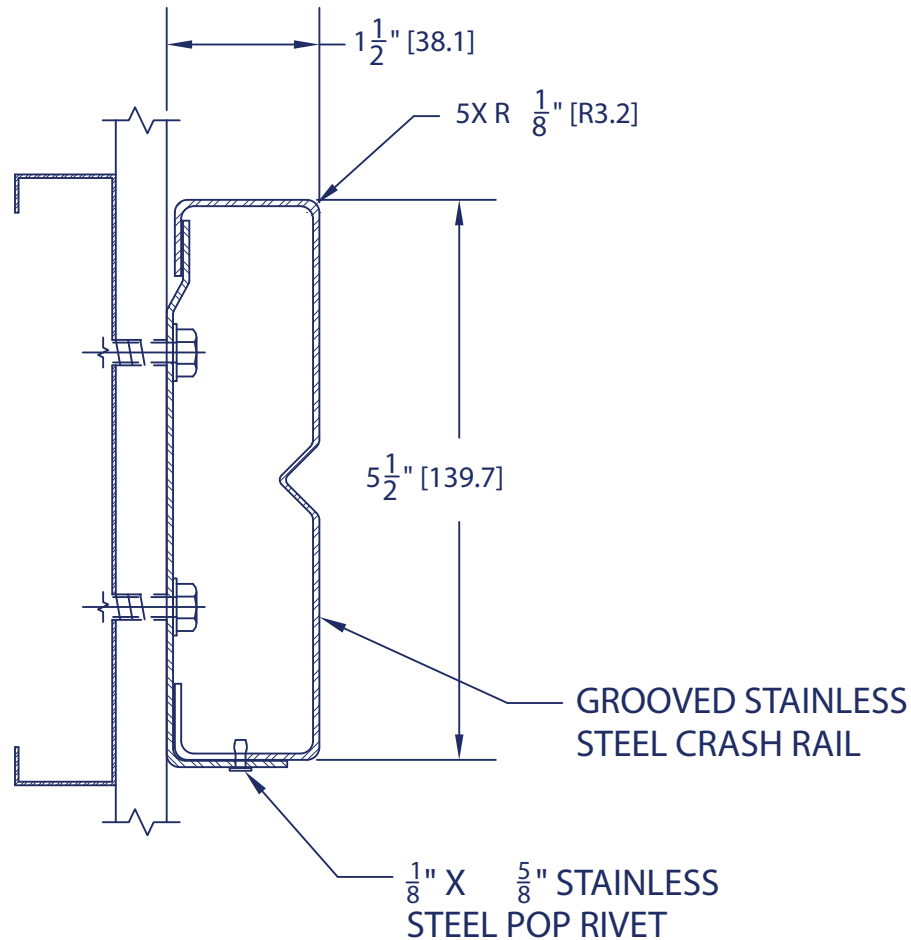

CS55, CRASH RAIL

SCALE: 1:2