

Koroseal Wall Protection Systems

H400 Handrail

Installation Instructions

Sheet #1

Recommended Installation Equipment: Radial Arm Saw or Power Miter Box with 12" (305mm) sharp carbide-tipped Alternating Tooth Bevel-Positive Hook 80-100 teeth blade, Power Biscuit Cutter, Tape Measure, Level, Chalk Line, Utility Knife, Drill, Drill Bits, Screwdriver, Sanding Block, Wood Glue, Removable Marker, Cleaning Cloth, and Suitable 1/4" x 5" (6mm x 127mm) Long Mounting Fastener.

1. Locate and install **KOROGARD®** Handrail in accordance with architectural drawings and specifications. When required, **KOROSEAL®** shop drawings should be used in conjunction with these documents.
2. Lay out work to be completed, including all component parts, along base of substrate (wall). Check material for any damage that may have incurred during shipment and/or handling at job site.
3. Snap chalk line at proper location on substrate to ensure level installation. Chalk line should be calculated to center line of mounting bracket wall fastener.

NOTE: Chalk line will be visible after installation and must be removed at cleanup.

4. Determine cut length of rail by locating ends on substrate; measure distance; and allow 12" (305mm) at end returns, 3" (76mm) at substrate inside corners, and 6" (152mm) at substrate outside corners. Mark Handrail at face of wood and miter-cut rail to appropriate length. Square-cut ends at end returns and outside corners and miter-cut ends at inside corners to 45° (see details). Use care to assure accurate and clean cuts.
5. Using a biscuit cutter, set blade for #20 biscuits and slot ends 7/8" (22mm) from core face of rail to match mating pieces except at 45° miter (inside corners); here locate slot 1-1/8" (29mm) from back of rail.

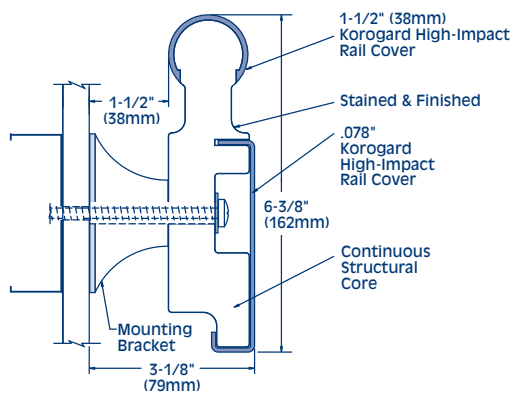
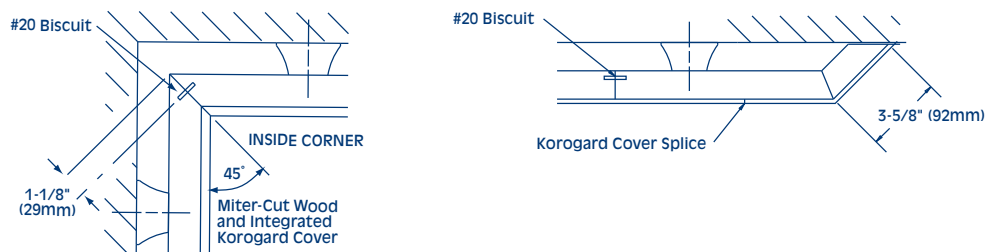

MODEL H400

Koroseal Wall Protection Systems

H400 Handrail

Installation Instructions

6. If structural cross-blocking has been incorporated in substrate construction, drill 9/32" (7mm) holes through handrail core along center line of recess at 3"-6" (76mm-152mm) in from each end of core and intermediate locations not exceeding 32" (813mm) O.C. Then place rail core in proper position on chalk line and mark hole locations on substrate. Drill holes in substrate using proper bit size for selected fasteners and proceed to instruction #9. If only vertical studding is available, refer to instruction #7.
7. Locate centers of vertical studs in substrate, place sized rail core in proper position against wall, and transfer locations of same to center line of recess. Drill 9/32" (7mm) holes through core along center line of retainer at these locations closest to each end of rail and at intermediate locations not greater than 32" (813mm) apart. Replace rail core in proper position on chalk line and mark hole locations on substrate. Drill holes in substrate using proper bit size for selected fasteners.
NOTE: In all cases, Handrail is to be anchored only to the structural framing of the substrate.
8. Before attaching ends/corners, also drill same anchor holes through end/corner pieces 3"-6" (76mm-152mm) in from end(s). Using wood glue (supplied by installer), glue #20 biscuits (supplied by **KOROSEAL**) in rail ends and trial-fit adjoining piece to assure proper fit. If satisfactory, assure that surfaces to be glued are clean and unfinished (sand if required) and glue adjoining parts together, carefully aligning parts. Allow glue to set and wipe any excess from joint with water-moistened cloth. Where possible, join parts prior to mounting rail to substrate.
9. Mount assembly to substrate using proper fastener (supplied by installer). Tighten securely.
NOTE: Prior to installation of protective KOROGARD® vinyl accent strip, make sure all fasteners are secured and properly seated.
10. Determine cut length of vinyl covers by measuring face of installed core. Cut ends of vinyl square or to 45°.
11. Install **KOROGARD** vinyl covers. Vinyl may be seated by holding at angle, placing top leg inside slot, and applying pressure to seat bottom leg into place. Press-fit grip cover over core.
12. Clean **KOROWOOD™** Handrail using water-moistened cloth. Use the **KOROWOOD** Touch-Up Kit provided to repair stained wood where minor damages or blemishes may have occurred during installation. Touch-Up Kits are not provided for "clear varnish" finished Handrail. Use MINWAX brand "Satin Sheen Polyurethane" or equal to overcoat repairs to all finishes.
13. If there are any questions, please call your local **KOROGARD** representative.



800-628-0449 • www.korogard.com • Division 10 26 00

Koroseal Wall Protection Systems

H400 Handrail

Installation Instructions

Model H400 is shown

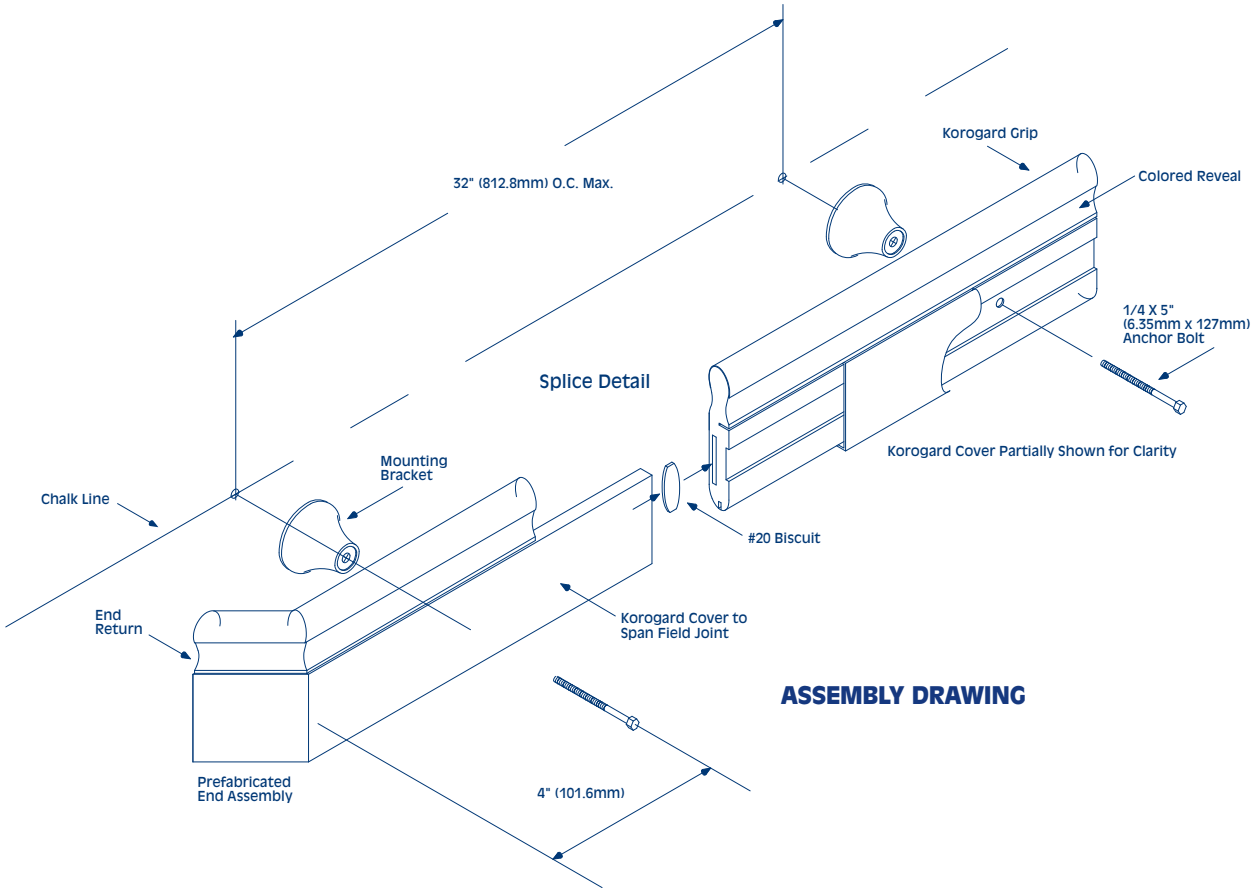

ASSEMBLY DRAWING

Koroseal Wall Protection Systems

H400 Handrail

Installation Instructions

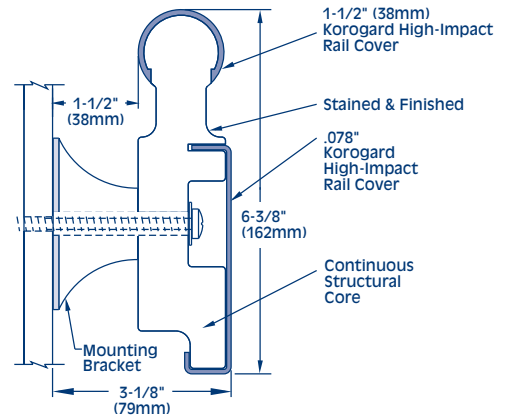
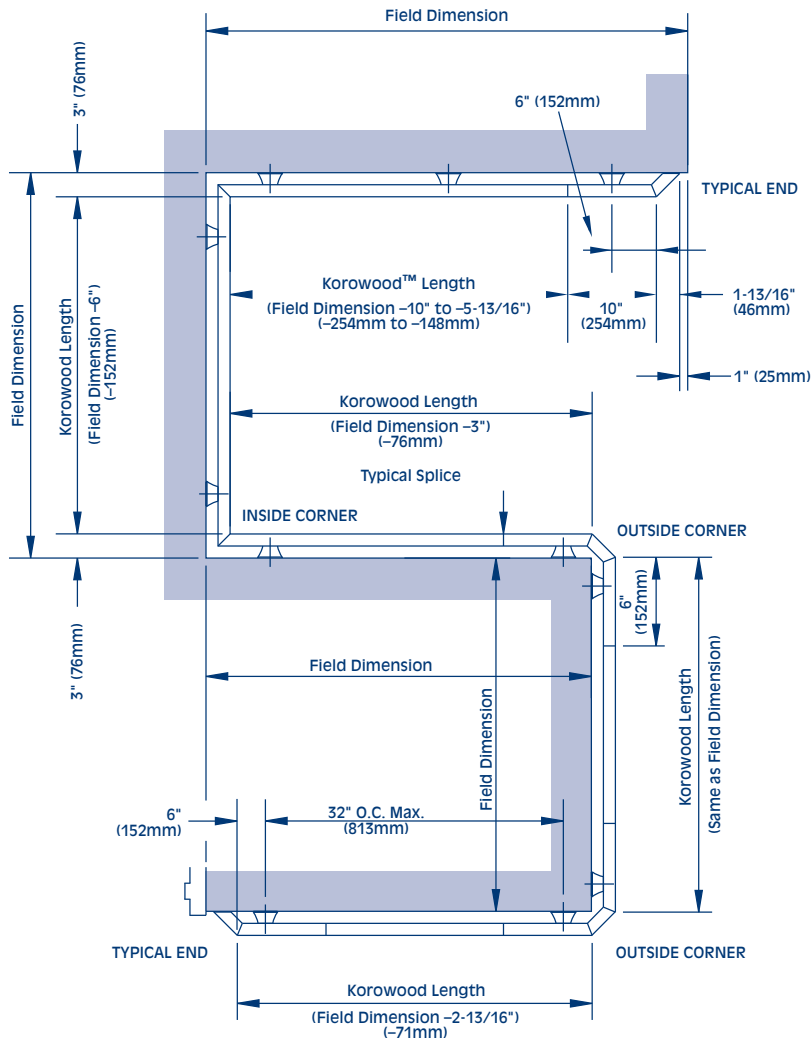

MODEL H400

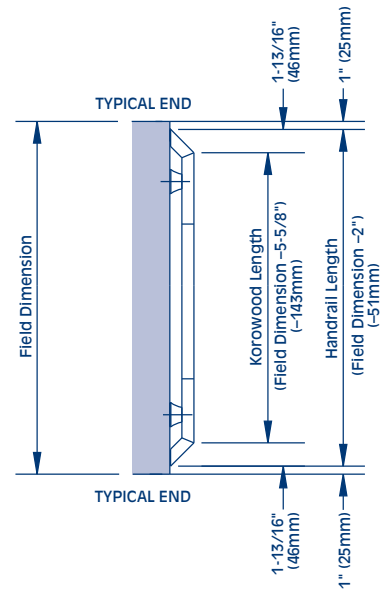

KOROGARD®
WALL PROTECTION SYSTEMS

800-628-0449 • www.korogard.com • Division 10 26 00