

# Koroseal Wall Protection Systems

## Korogard® B100-Series Bed Locators

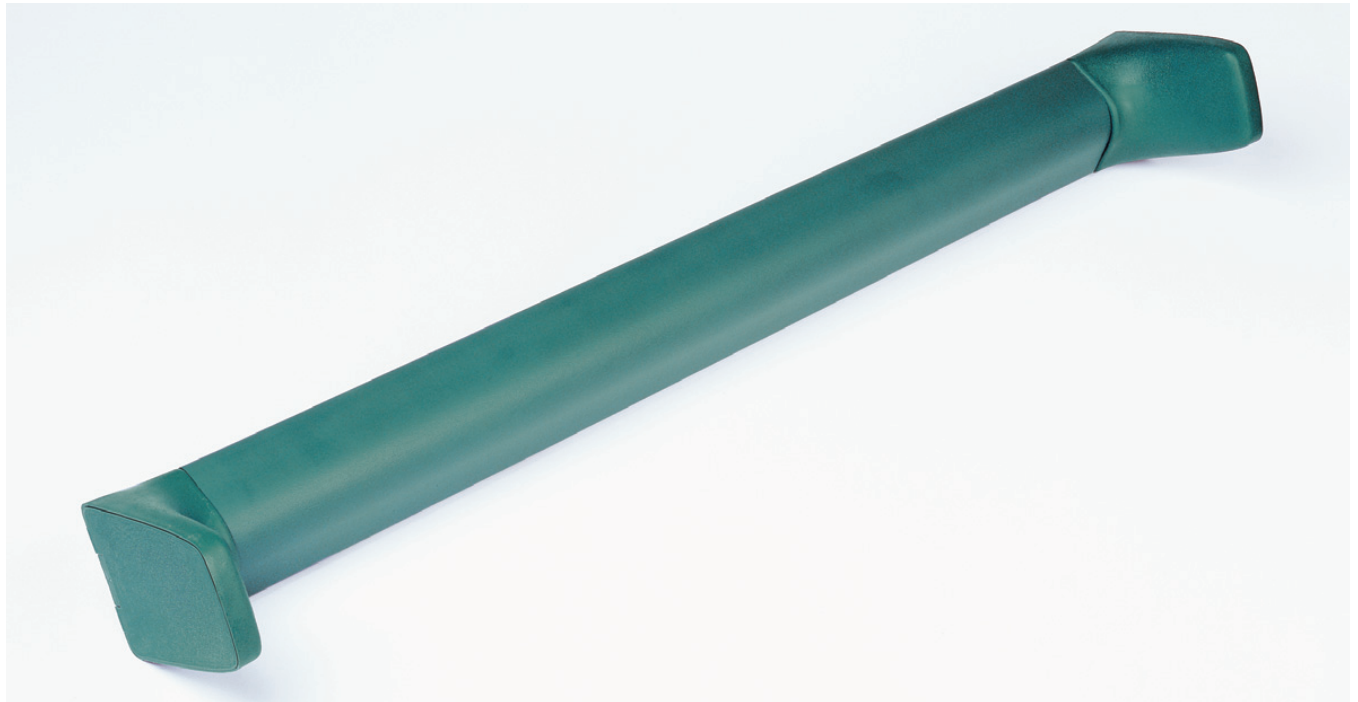

**KOROGARD** B100-Series Bed Locators are 3-1/2" (88.9mm) high rails with rounded full-length vinyl covers, continuous aluminum retainers, and locator caps. Bed Locators position beds in a safe, damage-free space. All units are precut and drilled with locator ends attached at the factory.

**KOROGARD** B100-Series Bed Locators are backed by a limited five-year warranty. All Bed Locators are Class I/A fire rated and meet national building code standards. All **KOROGARD** linear profiles color-coordinate with a multitude of **KOROSEAL**® Wallcoverings for a systems approach to wall protection.

B100 SERIES	ACCESSORY ITEMS
B121	Bed Locator End Cap
B103	90° Outside Corner Cap
B105	Splice Kit

For more information on **KOROGARD** Bed Locators or the **KOROSEAL** Wall Protection System, please call your local **KOROGARD** distributor or 800-628-0449.

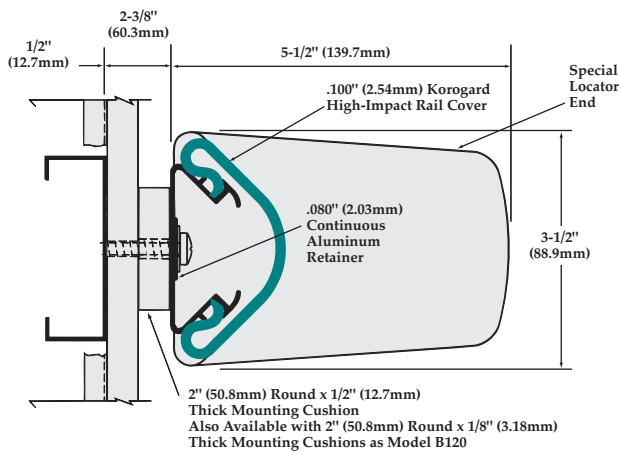

**B130**

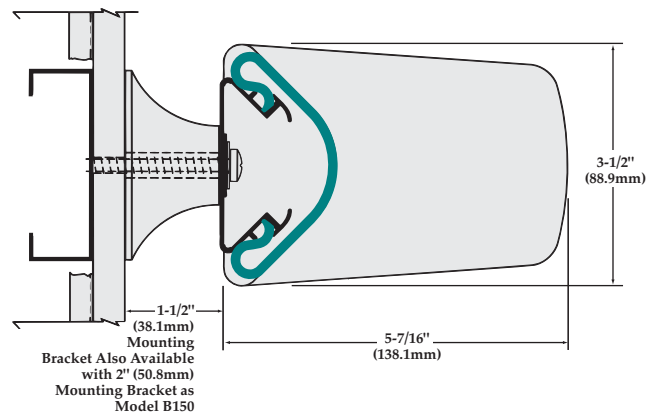

**B140**

# Product Guide Specification

## SECTION 10 26 00 BED LOCATORS

### PART 1 GENERAL

#### 1.01 SECTION INCLUDES

3-1/2" (88.9mm) Bed Locators.

#### 1.02 SUBMITTALS

- A. Comply with requirements of Section 01 33 00—Submittals.
- B. Product Data: Submit manufacturer's product data.
- C. Shop Drawings: Submit shop drawings showing components, dimensions, and anchorage details.
- D. Samples: Submit 12" (304.8mm) long sample of each model and color specified, including end caps and corner units, for Architect's approval.
- E. Certification: Submit manufacturer's certification indicating compliance with ADA requirements.

#### 1.03 QUALITY ASSURANCE

Comply with NFPA 101® for interior finish materials. Smoke developed less than 450 and flame spread of 25 or less in accordance with ASTM E 84.

#### 1.04 DELIVERY, STORAGE, AND HANDLING

- A. Delivery: Deliver materials to site in manufacturer's original, unopened containers and packaging with labels clearly indicating manufacturer and material.
- B. Storage: Store materials indoors in a clean, dry area protected from damage and in accordance with manufacturer's instructions.
- C. Handling: Protect materials during handling and installation to prevent damage.

### PART 2 PRODUCTS

#### 2.01 MANUFACTURER

Koroseal Wall Protection Systems,  
A Division of RJF International Corporation.

#### 2.02 BED LOCATORS

Koroseal "Korogard" B100-Series Bed Locator: Bed Locator mounted over continuous aluminum retainer. Exposed surfaces shall be free of wrinkling, chipping, discoloration, or other imperfections.

1. Dimensions:
  - a. Height: 3-1/2" (88.9mm).
  - b. Width: 1-7/8" (47.6mm).
  - c. Clearance from Wall: [Model B120, 1/8" (3.18mm)] [Model B130, 1/2" (12.7mm)] [Model B140, 1-1/2" (38.1mm)] [Model B150, 2" (50.8mm)].
2. Profile: High-impact vinyl acrylic extrusion locked in place, nominal 0.100" (2.54mm) thick. Class I/A fire rating, tested in accordance with ASTM E 84.
3. Extrusion: Pebble grain finish. Contains EPA registered Micro-Chek antimicrobial agent.
4. Retainer: Continuous 6063-T6 aluminum retainer along entire length of Bed Locator, minimum 0.080" (2.03mm) thick.
5. End Caps: Injection molded, preassembled locator unit of color and texture similar to that of rail.

### PART 3 EXECUTION

#### 3.01 EXAMINATION

Inspect wall surfaces to receive Bed Locators. Notify the Architect in writing if wall surfaces are not acceptable. Do not begin installation until unacceptable conditions have been corrected.

#### 3.02 INSTALLATION

- A. Install Bed Locators to walls securely in accordance with manufacturer's written instructions.
- B. Install Bed Locators accurately in location, alignment, and elevation.
- C. Provide horizontal steel stud back-up in drywall stud cavity to accept fasteners.



**KOROGARD®**  
WALL PROTECTION SYSTEMS

800-628-0449 • [www.korogard.com](http://www.korogard.com) • Division 10 26 00