

# Koroseal Wall Protection Systems

## Korogard® G200-Series

### Surface-Mounted Corner Guards



**KOROGARD** G200-Series Corner Guards consist of a formidable 3" (76.2mm) vinyl 1/4" (6.35mm) radius cover mounted over a continuous aluminum retainer. **KOROGARD** Corner Guards are an attractive and durable solution to unsightly, damaged corners. G200-Series Surface-Mounted Corner Guards provide support in medium- to high-impact areas. The G200 is available as G20E, a **KOROGARD ETS** product manufactured with a unique blend of high-performance materials and recycled aluminum. The G210 Model is available for 135° angle corners.

**KOROGARD** G200-Series Corner Guards are backed by a limited five-year warranty. All Corner Guards are Class I/A fire rated and meet national building code standards. All **KOROGARD** linear profiles color-coordinate with a multitude of **KOROSEAL®** Wallcoverings for a systems approach to wall protection.

For more information on **KOROGARD** Corner Guards or the **KOROSEAL** Wall Protection System, please call your local **KOROGARD** distributor or 800-628-0449.

G200 SERIES	ACCESSORY ITEMS
G201	Standard End Cap
G211	135° End Cap

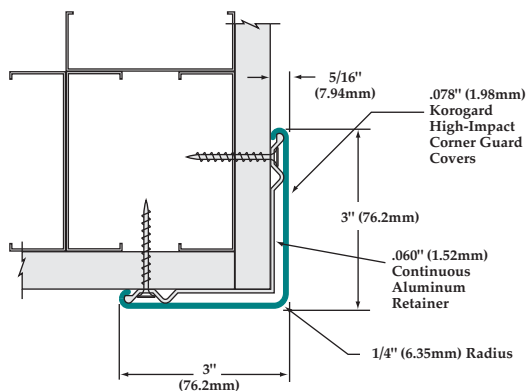

**G200/G20E**

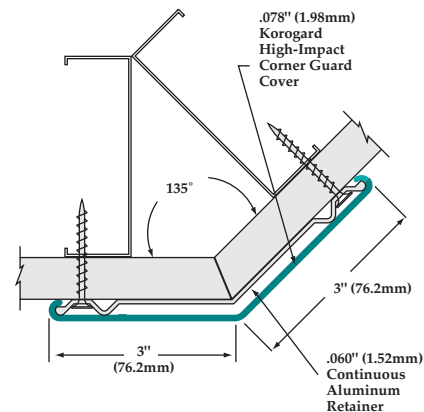

**G210**

# Product Guide Specification

## SECTION 10 26 00 CORNER GUARDS

### PART 1 GENERAL

#### 1.01 SECTION INCLUDES

3" x 3" (76.2mm x 76.2mm) Corner Guards.

#### 1.02 SUBMITTALS

- A. Comply with requirements of Section 01 33 00—Submittals.
- B. Product Data: Submit manufacturer's product data.
- C. Shop Drawings: Submit shop drawings showing components, dimensions, and anchorage details.
- D. Samples: Submit 12" (304.8mm) long sample of each model and color specified, including end caps, for Architect's approval.
- E. Certification: Submit manufacturer's certification indicating compliance with ADA requirements.

#### 1.03 QUALITY ASSURANCE

Comply with NFPA 101® for interior finish materials. Smoke developed less than 450 and flame spread of 25 or less in accordance with ASTM E 84.

#### 1.04 DELIVERY, STORAGE, AND HANDLING

- A. Delivery: Deliver materials to site in manufacturer's original, unopened containers and packaging with labels clearly indicating manufacturer and material.
- B. Storage: Store materials indoors in a clean, dry area protected from damage and in accordance with manufacturer's instructions.
- C. Handling: Protect materials during handling and installation to prevent damage.

### PART 2 PRODUCTS

#### 2.01 MANUFACTURER

Koroseal Wall Protection Systems,  
A Division of RJF International Corporation.

#### 2.02 CORNER GUARD SYSTEMS

Koroseal "Korogard" G200-Series Corner Guard: Corner Guard mounted over continuous aluminum retainer. Exposed surfaces shall be free of wrinkling, chipping, discoloration, or other imperfections.

1. Dimensions
  - a. Leg Length: 3" (76.2mm).
  - b. Angle: 90° = G200; 135° = G210.
2. Profile: High-impact vinyl acrylic extrusion locked in place, nominal 0.078" (1.98mm) thick. Class I/A fire rating, tested in accordance with ASTM E 84.
3. Extrusion: Pebble grain finish. Contains EPA registered Micro-Chek antimicrobial agent.
4. Retainer: Continuous 6063-T6 aluminum retainer along entire length of Corner Guard, minimum 0.060" (1.52mm) thick.
5. End Caps: Injection molded unit of color and texture similar to that of Corner Guard.

### PART 3 EXECUTION

#### 3.01 EXAMINATION

Inspect wall surfaces to receive Corner Guards. Notify the Architect in writing if wall surfaces are not acceptable. Do not begin installation until unacceptable conditions have been corrected.

#### 3.02 INSTALLATION

- A. Install Corner Guards to walls securely in accordance with manufacturer's written instructions.
- B. Install Corner Guards accurately in location, alignment, and elevation.



**KOROGARD®**  
WALL PROTECTION SYSTEMS

800-628-0449 • [www.korogard.com](http://www.korogard.com) • Division 10 26 00