

Koroseal Wall Protection Systems

Korogard® G400-Series

Surface-Mounted Corner Guards



KOROGARD G400-Series Corner Guards consist of a formidable 2-11/16" (68.3mm) vinyl 1-1/4" (31.8mm) radius cover mounted over a continuous aluminum retainer. **KOROGARD** Corner Guards are an attractive and durable solution to unsightly, damaged corners. G400-Series Surface-Mounted Corner Guards provide support in high-impact areas.

KOROGARD G400-Series Corner Guards are backed by a limited five-year warranty. All Corner Guards are Class I/A fire rated and meet national building code standards. All **KOROGARD** linear profiles color-coordinate with a multitude of **KOROSEAL**® Wallcoverings for a systems approach to wall protection.

For more information on **KOROGARD** Corner Guards or the **KOROSEAL** Wall Protection System, please call your local **KOROGARD** distributor or 800-628-0449.

G400 SERIES

G401

ACCESSORY ITEM

Standard End Cap

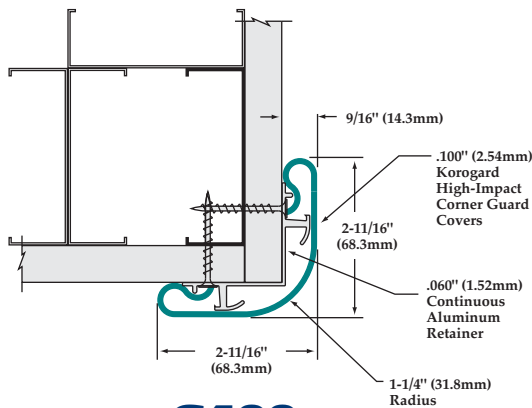

G400

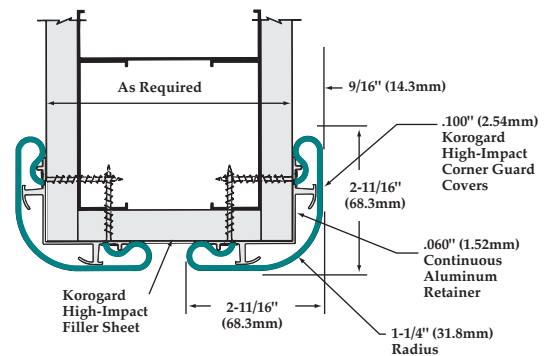

G410

Product Guide Specification

SECTION 10 26 00 CORNER GUARDS

PART 1 GENERAL

1.01 SECTION INCLUDES

2-11/16" x 2-11/16" (68.3mm x 68.3mm) Corner Guards.

1.02 SUBMITTALS

- A. Comply with requirements of Section 01 33 00—Submittals.
- B. Product Data: Submit manufacturer's product data.
- C. Shop Drawings: Submit shop drawings showing components, dimensions, and anchorage details.
- D. Samples: Submit 12" (304.8mm) long sample of each model and color specified, including end caps, for Architect's approval.
- E. Certification: Submit manufacturer's certification indicating compliance with ADA requirements.

1.03 QUALITY ASSURANCE

Comply with NFPA 101® for interior finish materials. Smoke developed less than 450 and flame spread of 25 or less in accordance with ASTM E 84.

1.04 DELIVERY, STORAGE, AND HANDLING

- A. Delivery: Deliver materials to site in manufacturer's original, unopened containers and packaging with labels clearly indicating manufacturer and material.
- B. Storage: Store materials indoors in a clean, dry area protected from damage and in accordance with manufacturer's instructions.
- C. Handling: Protect materials during handling and installation to prevent damage.

PART 2 PRODUCTS

2.01 MANUFACTURER

Koroseal Wall Protection Systems,
A Division of RJF International Corporation.

2.02 CORNER GUARD SYSTEMS

Koroseal "Korogard" G400-Series Corner Guard: Corner Guard mounted over continuous aluminum retainer. Exposed surfaces shall be free of wrinkling, chipping, discoloration, or other imperfections.

1. Dimensions
 - a. Leg Length: 2-11/16" (68.3mm).
 - b. Angle: 90°.
2. Profile: High-impact vinyl acrylic extrusion locked in place, nominal 0.100" (2.54mm) thick. Class I/A fire rating, tested in accordance with ASTM E 84.
3. Extrusion: Pebble grain finish. Contains EPA registered Micro-Chek antimicrobial agent.
4. Retainer: Continuous 6063-T6 aluminum retainer along entire length of Corner Guard, minimum 0.060" (1.52mm) thick.
5. End Caps: Injection molded unit of color and texture similar to that of Corner Guard.

PART 3 EXECUTION

3.01 EXAMINATION

Inspect wall surfaces to receive Corner Guards. Notify the Architect in writing if wall surfaces are not acceptable. Do not begin installation until unacceptable conditions have been corrected.

3.02 INSTALLATION

- A. Install Corner Guards to walls securely in accordance with manufacturer's written instructions.
- B. Install Corner Guards accurately in location, alignment, and elevation.



800-628-0449 • www.korogard.com • Division 10 26 00