

Koroseal Wall Protection Systems

Korogard® C400-Series Crash Rails



KOROGARD C400-Series Crash Rails are 4" (101.6mm) high with a continuous aluminum retainer. C400-Series Crash Rails combine a simple design element and a variety of mounting options to meet every impact need. **KOROGARD** rugged durability makes C400-Series Crash Rails best suited for medium- to high-impact areas. The C400 is available as C40E, a **KOROGARD ETS** product manufactured with a unique blend of high-performance materials and recycled aluminum.

C400 SERIES	ACCESSORY ITEMS
C401	Standard End Cap
C403	90° Corner Cap
C404	135° Corner Cap
C405	Splice Kit
C441	Extended End Cap

KOROGARD C400-Series Crash Rails are backed by a limited five-year warranty. All Crash Rails are Class I/A fire rated and meet national building code standards. All **KOROGARD** linear profiles color-coordinate with a multitude of **KOROSEAL**® Wallcoverings for a systems approach to wall protection.

For more information on **KOROGARD** Crash Rails or the **KOROSEAL** Wall Protection System, please call your local **KOROGARD** distributor or 800-628-0449.

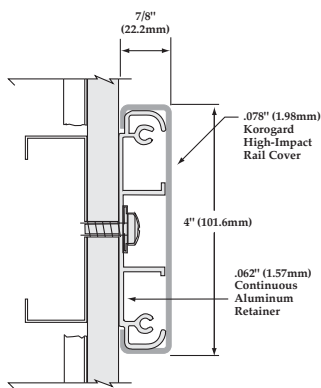

C400/C40E

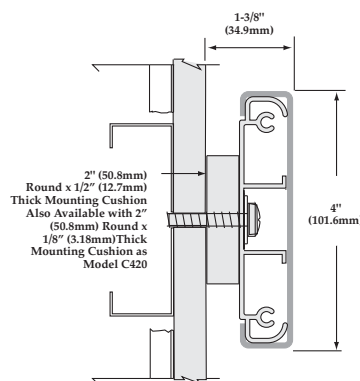

C430

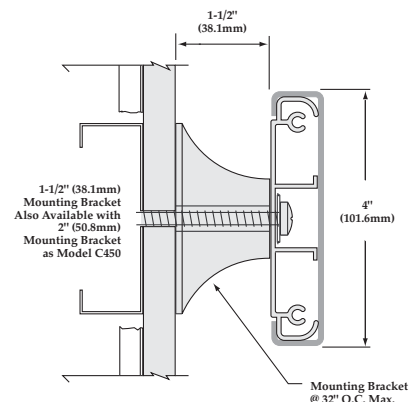

C440

Product Guide Specification

SECTION 10 26 00 CRASH RAILS

PART 1 GENERAL

1.01 SECTION INCLUDES

- 4" (101.6mm) Crash Rails.

1.02 SUBMITTALS

- Comply with requirements of Section 01 33 00—Submittals.
- Product Data: Submit manufacturer's product data.
- Shop Drawings: Submit shop drawings showing components, dimensions, and anchorage details.
- Samples: Submit 12" (304.8mm) long sample of each model and color specified, including end caps and corner units for Architect's approval.
- Certification: Submit manufacturer's certification indicating compliance with ADA requirements.

1.03 QUALITY ASSURANCE

Comply with NFPA 101® for interior finish materials. Smoke developed less than 450 and flame spread of 25 or less in accordance with ASTM E 84.

1.04 DELIVERY, STORAGE, AND HANDLING

- Delivery: Deliver materials to site in manufacturer's original, unopened containers and packaging with labels clearly indicating manufacturer and material.
- Storage: Store materials indoors in a clean, dry area protected from damage and in accordance with manufacturer's instructions.
- Handling: Protect materials during handling and installation to prevent damage.

PART 2 PRODUCTS

2.01 MANUFACTURER

Koroseal Wall Protection Systems,
A Division of RJF International Corporation.

2.02 CRASH RAILS

Koroseal "Korogard" C400-Series Crash Rail:
Crash Rail mounted over continuous aluminum retainer.
Exposed surface shall be free of wrinkling, chipping,
and discoloration.

- Dimensions:
 - Height: 4" (101.6mm).
 - Width: 7/8" (22.2mm).
 - Clearance from Wall: [Model C400, flush with wall] [Model C420, 1/8" (3.18mm)] [Model C430, 1/2" (12.7mm)] [Model C440, 1-1/2" (38.1mm)] [Model C450, 2" (50.8mm)].

- Profile: High-impact vinyl acrylic extrusion locked in place, nominal 0.078" (1.98mm) thick. Class I/A fire rating, tested in accordance with ASTM E 84.
- Extrusion: Pebble grain finish. Contains EPA registered Micro-Chek antimicrobial agent.
- Retainer: Minimum 0.062" (1.57mm) thick 6063-T6 aluminum.
- End Caps: Injection molded preassembled wall return unit of color and texture similar to that of rail.
- Corners: Internal and External corner units of similar material to end cap units. Carry line of Crash Rail continuously around corner, unless otherwise indicated on drawings.
- Color: Color to be selected by Architect from manufacturer's standard colors.

PART 3 EXECUTION

3.01 EXAMINATION

Inspect wall surfaces to receive Crash Rails. Notify the Architect in writing if wall surfaces are not acceptable. Do not begin installation until unacceptable conditions have been corrected.

3.02 INSTALLATION

- Install Crash Rails to walls securely in accordance with manufacturer's written instructions.
- Install Crash Rails accurately in location, alignment, and elevation.
- Provide horizontal steel stud back-up in drywall stud cavity to accept fasteners.



KOROGARD®
WALL PROTECTION SYSTEMS

800-628-0449 • www.korogard.com • Division 10 26 00